



Switch Amplifier

HiC2831R1

- 1-channel isolated barrier
- 24 V DC supply (bus powered)
- Dry contact or NAMUR input
- Application-specific outputs
- Usable as signal splitter (1 input and 2 outputs)
- 2 passive transistor outputs (resistive)
- Line fault detection (LFD)
- Line fault transparency (LFT)
- Reversible mode of operation
- Up to SIL 2 (SC 3) acc. to IEC/EN 61508



Function

This isolated barrier is used for intrinsic safety applications.

The device transfers digital signals (NAMUR sensors/mechanical contacts) from the explosion-hazardous area to the non-explosion-hazardous area.

The input controls two passive transistor outputs with a resistive output characteristic.

The outputs have three defined states: 1-signal = 6.5 V voltage drop, 0-signal = 33 kΩ and 6.5 V voltage drop and fault > 100 kΩ.

This output characteristic offers line fault transparency on the signal lines.

Via switches the mode of operation can be reversed and the line fault detection can be switched off.

During a fault state, the passive transistor outputs switch to their fault state and LEDs indicate the fault according to NAMUR NE 44. A separate fault bus is available. This fault bus can be monitored if the termination board supports a module fault detection.

This device mounts on a HiC termination board.

Application

This device is compatible to the control:

- Yokogawa ProSafe DI card SDV144

Compatibility check to other ESD/DCS systems on request.

Connection

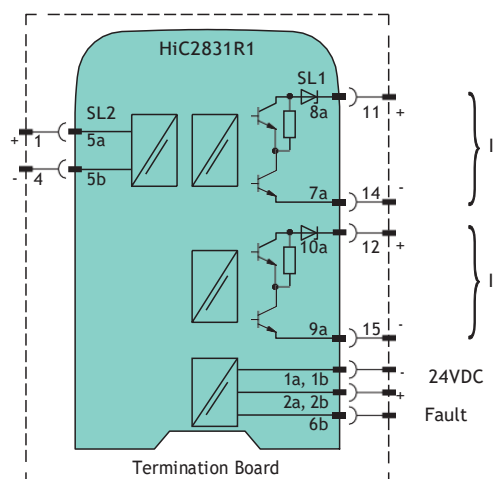
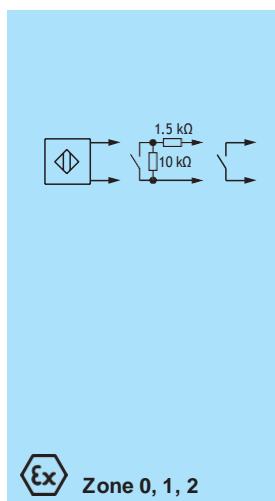

Zone 2

Technical Data

General specifications

Signal type Digital Input

Functional safety related parameters

Refer to "General Notes Relating to Pepperl+Fuchs Product Information".

Pepperl+Fuchs Group
www.pepperl-fuchs.com

Iran: +9821 91007267
info@omranniroo.com

Germany: +49 621 776 2222
pa-info@de.pepperl-fuchs.com

Singapore: +65 6779 9091
pa-info@sg.pepperl-fuchs.com

PF PEPPERL+FUCHS

Safety Integrity Level (SIL)		SIL 2
Systematic capability (SC)		SC 3
Supply		
Connection		SL1: 1a(-), 1b(-); 2a(+), 2b(+)
Rated voltage	U_r	19 ... 30 V DC bus powered via Termination Board
Ripple		$\leq 10 \%$
Rated current	I_r	$\leq 25 \text{ mA}$
Power dissipation		$\leq 500 \text{ mW}$
Power consumption		$\leq 600 \text{ mW}$
Input		
Connection side		field side
Connection		SL2: 5a(+), 5b(-)
Rated values		acc. to EN 60947-5-6 (NAMUR), see manual for electrical data
Open circuit voltage/short-circuit current		approx. 10 V DC / approx. 8 mA
Switching point/switching hysteresis		1.2.....2.1 mA / approx. 0.2 mA
Line fault detection		breakage $I \leq 0.1 \text{ mA}$, short-circuit $I \geq 6.5 \text{ mA}$
Pulse/Pause ratio		min. 100 μs / min. 100 μs
Output		
Connection side		control side
Connection		SL1: 8a(+), 7a(-); 10a(+), 9a(-)
Rated voltage	U_r	19 ... 30 V DC with external resistance $> 2 \text{ k}\Omega$, e. g. 16-channel ProSafe DI card SDV144 from Yokogawa
Response time		$\leq 200 \mu\text{s}$
Output I, II		signal or fault message, passive transistor output (resistive) 0-signal: $33 \text{ k}\Omega \pm 5 \%$ + voltage drop $6.5 \text{ V} \pm 0.5 \text{ V}$ 1-signal: voltage drop $6.5 \text{ V} \pm 0.5 \text{ V}$ fault: $> 100 \text{ k}\Omega$
Fault indication output		
Connection		SL1: 6b
Output type		open collector transistor (internal fault bus)
Transfer characteristics		
Switching frequency		$\leq 5 \text{ kHz}$
Galvanic isolation		
Output/power supply		basic insulation according to IEC/EN 61010-1, rated insulation voltage $60 V_{\text{eff}}$
Output/Output		basic insulation according to IEC/EN 61010-1, rated insulation voltage $60 V_{\text{eff}}$
Indicators/settings		
Display elements		LEDs
Control elements		DIP switch
Configuration		via DIP switches
Labeling		space for labeling at the front
Directive conformity		
Electromagnetic compatibility		
Directive 2014/30/EU		EN 61326-1:2013 (industrial locations)
Conformity		
Electromagnetic compatibility		EN IEC 61326-3-2:2018 , NE 21:2017 For further information see system description.
Degree of protection		IEC 60529:2001
Protection against electrical shock		IEC 61010-1
Ambient conditions		
Ambient temperature		$-40 \dots 70 \text{ }^\circ\text{C}$ ($-40 \dots 158 \text{ }^\circ\text{F}$)
Mechanical specifications		
Degree of protection		IP20
Mass		approx. 90 g
Dimensions		12.5 x 106 x 128 mm (0.5 x 4.2 x 5.1 inch) (W x H x D)
Mounting		on termination board

Technical Data

Coding	pin 1 and 2 trimmed For further information see system description.		
Data for application in connection with hazardous areas			
EU-type examination certificate	BVS 11 ATEX E 026		
Marking	1 II (1)G [Ex ia Ga] IIC 1 II (1)D [Ex ia Da] IIIC 1 I (M1) [Ex ia Ma] I		
Input	Ex ia		
Voltage	U _o	10.5 V	
Current	I _o	17.1 mA	
Power	P _o	45 mW (linear characteristic)	
Supply			
Maximum safe voltage	U _m	253 V AC (Attention! U _m is no rated voltage.)	
Output			
Maximum safe voltage	U _m	253 V AC (Attention! U _m is no rated voltage.)	
Certificate	KIWA 15 ATEX 0037 X		
Marking	1 II 3G Ex ec IIC T4 Gc		
Galvanic isolation			
Input/Output	safe electrical isolation acc. to IEC/EN 60079-11, voltage peak value 375 V		
Input/power supply	safe electrical isolation acc. to IEC/EN 60079-11, voltage peak value 375 V		
Directive conformity			
Directive 2014/34/EU	EN IEC 60079-0:2018+AC:2020 , EN 60079-11:2012 , EN 60079-7:2015+A1:2018 , EN 50303:2000		
International approvals			
FM approval			
Control drawing	116-0430 (cFMus)		
UL approval			
Control drawing	116-0331		
IECEx approval			
IECEx certificate	IECEx BVS 11.0040 IECEx KIWA 15.0019X		
IECEx marking	[Ex ia Ga] IIC , [Ex ia Da] IIIC , [Ex ia Ma] I , Ex ec IIC T4 Gc		
General information			
Supplementary information	Observe the certificates, declarations of conformity, instruction manuals, and manuals where applicable. For information see www.pepperl-fuchs.com .		

Assembly

Front view

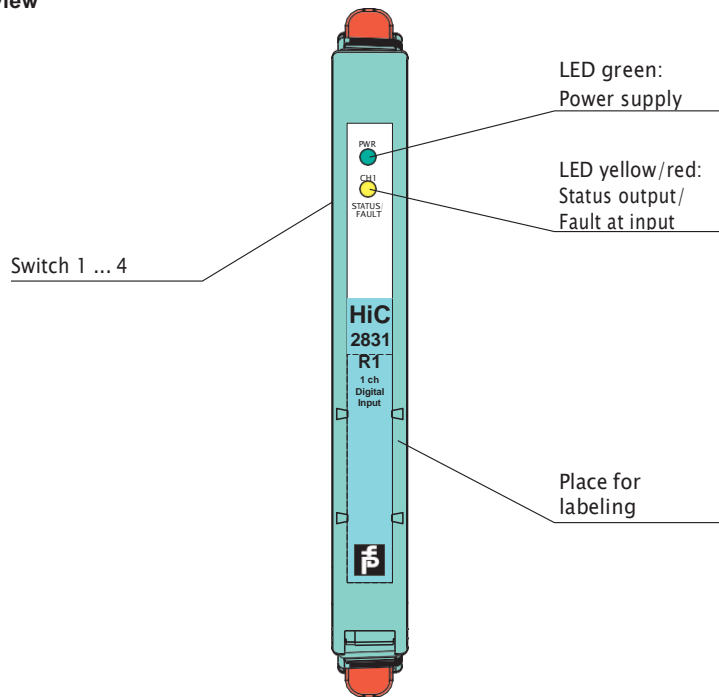

Configuration

Configure the device in the following way:

- Push the red Quick Lok Bars on each side of the device in the upper position.
- Remove the device from termination board.
- Set the switches according to the figure in the **Configuration** section.

Note

The pins for this device are trimmed to polarize it according to its safety parameters. Do not change the setting. For further information see system description.

Configuration

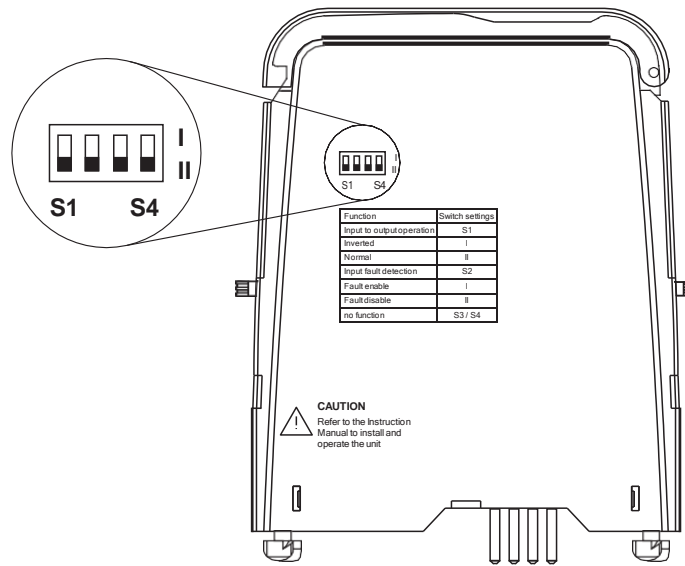

Switch settings

S	Function	Position	
1	Mode of operation	Inverted	I
		Normal	II
2	Input line fault detection	ON	I
		OFF	II
3	no function		
4	no function		

Characteristic Curve

Switch points

